

AME 3623 Real-Time Embedded Systems
Final Exam
May 7, 2018

General instructions:

- Please wait to open this exam booklet until you are told to do so.
- This examination booklet has 14 pages. You also have been issued a bubble sheet.
- Write your name, university ID number and date below, and sign where indicated. Also, write your name and ID number on your bubble sheet, and fill in the bubbles for your ID.
- The exam is closed book, notes and electronic devices. The exception is that you may have one page of personal notes (double sided).
- The exam is worth a total of 274 points (and 20% of your final grade).
- You have 2 hours to complete the exam. Be a smart test taker: if you get stuck on one problem go on to the next.
- Use your bubble sheet to answer all multiple-choice questions. Make sure that the question number and the bubble row number match when you are answering each question. Use the provided space in this exam booklet to answer the FSM drawing questions.

On my honor, I affirm that I have neither given nor received inappropriate aid in the completion of this exam.

Signature: _____ **Name:** _____

ID Number: _____ **Date:** _____

Question	Points	Score
Number Representations and Operations	45	
Circuits	45	
Circuits and Code	61	
Control	24	
Interrupt Service Routines	23	
Serial Processing	20	
Digital-Analog Systems	16	
Finite State Machines	40	
Total:	274	

Part I. Number Representations and Operations

1. (5 points) What is the decimal representation of b after the following code is executed?

```
uint8_t a = 20;
uint8_t b = 14 * (a / 3);
```

A. 80 **B. 84** C. 93 D. 93.3333... E. Answer not shown

2. (5 points) What is the decimal value of c after the following code is executed? Assume a “12.4” fixed-point representation.

```
uint16_t a = 0x23;
uint16_t b = 0x13;
uint16_t c = fixed_point_sub(a, b);
```

A. 0x0 **B. 0x10** C. 0x100 D. 0x160 E. Answer not shown

3. (5 points) What is the hexadecimal representation of c after the following code is executed?

```
uint8_t a = 0x27;
uint8_t b = 0x26;
uint8_t c = (a ^ 10) & b;    // XOR
```

A. 0x24 B. 0x26 C. 0x27 D. 0x28 E. Answer not shown

4. (5 points) What is the binary representation for $-0x18$? Assume a signed, 8-bit integer.

A. 0001 0010 B. 0001 1000 **C. 1110 1000** D. 1110 1110
E. Answer not shown

5. (5 points) What is the binary representation of a after the following code is executed?

```
uint8_t a = 0x7C;
```

A. 0110 1010 B. 0110 1110 **C. 0111 1100** D. 0111 1110
E. Answer not shown

6. (5 points) What is the minimum value that can be represented with an **unsigned**, “4.4” fixed-point number?

A. $7\frac{7}{8}$ B. $7\frac{15}{16}$ C. $15\frac{7}{8}$ D. $15\frac{15}{16}$ **E. Answer not shown**

7. (5 points) What is printed by the following code block?

```
int8_t a = 0x92;  
Serial.printf("%d\n", a)
```

- A. -146 **B. -110** C. 92 D. 146 E. Answer not shown
8. (5 points) What is the hexadecimal fixed-point representation of 17.125 using “12.4” fixed-point?
- A. 0x101 B. 0x102 C. 0x111 **D. 0x112** E. Answer not shown
9. (5 points) What is the decimal value of c after the following code is executed? Assume a “4.4” fixed-point representation.

```
uint8_t a = 4;  
uint8_t b = 20;  
uint8_t c = fixed_point_div(a, b);
```

- A. 0 B. 2 **C. 3** D. 4 E. Answer not shown

Part II. Circuits

10. (5 points) Given the following circuit and $R = 200\Omega$, $V_1 = 6V$ and $V_2 = 2V$. What is I ?

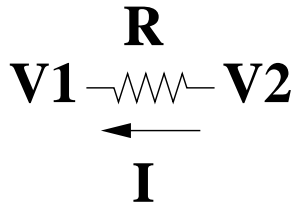

- A. -30 mA B. -20 mA C. -10 mA D. 10 mA E. Answer not shown

Consider the following circuit:

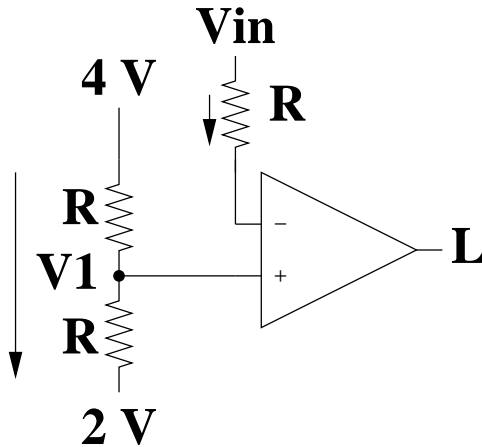

Assume that $R = 250\Omega$ and that L is a logical output.

11. (8 points) If $V_{in} = 7\text{ V}$, what is V_1 ?
 A. 1 V B. 2 V C. 3 V D. 4 V E. Answer not shown
12. (8 points) If $V_{in} = 6.5\text{ V}$, what is L ?
 A. True B. **False** C. Answer not shown
13. (8 points) If $V_{in} = 1.5\text{ V}$, what is L ?
 A. **True** B. False C. Answer not shown

Consider the following circuit:

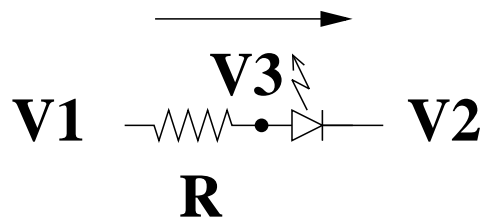

Assume that $V_f = 2V$ and $R = 1000\Omega$.

14. (8 points) If $V_2 = 4V$, $V_3 = 3V$, what is V_1 ?
A. $1V$ B. $2V$ C. $3V$ D. $4V$ E. Answer not shown

15. (8 points) If $I_D = 10mA$, $V_3 = 0V$, what is V_1 ?
A. $-2V$ B. $1V$ C. $2V$ D. $10V$ E. Answer not shown

Part III. Circuits and Code

Consider the following circuit:

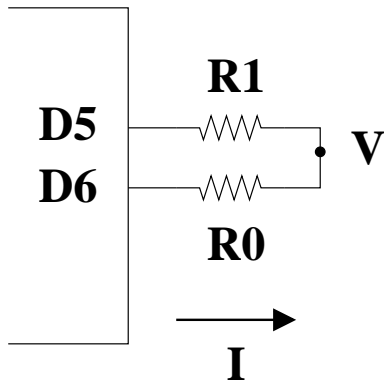

Assume $R_0 = 50\Omega$, $R_1 = 200\Omega$ and the maximum voltage output by a microprocessor pin is $5V$.

16. (5 points) What is the correct initialization for *PORTD_PDDR*?
A. $0x03$ B. $0x30$ C. $0x60$ D. $0xC0$ E. Answer not shown

17. (8 points) If *PORTD_PDOR* = $0x46$, what is V ?
A. $0V$ B. $1V$ C. $4V$ D. $5V$ E. Answer not shown

18. (8 points) If *PORTD_PDOR* = $0xA8$, what is V ?
A. $0V$ B. $1V$ C. $4V$ D. $5V$ E. Answer not shown

19. (8 points) If *PORTD_PDOR* = $0x95$, what is V ?
A. $0V$ B. $1V$ C. $4V$ D. $5V$ E. Answer not shown

Consider the following circuit:

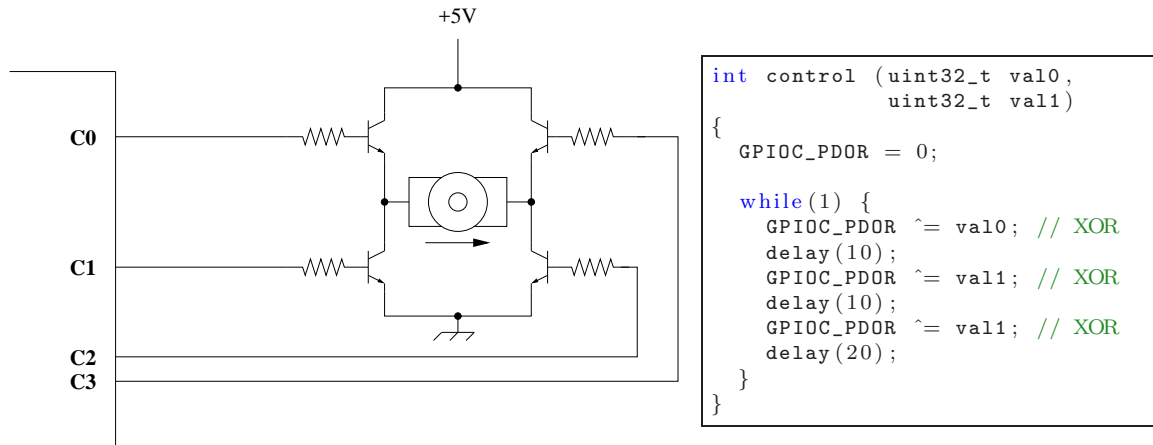

Assume that Port C, pins 0..3 are configured as digital output pins. Also assume that the motor can be modeled as a 2Ω resistor.

20. (8 points) When $val0 = 0x0$ and $val1 = 0x0$, what is the duty cycle of the signal on C3?
 - A. 0%
 - B. 25%
 - C. 50%
 - D. 100%
 - E. Answer not shown
21. (8 points) When $val0 = 0x5$ and $val1 = 0x0$, what is the duty cycle that the motor is being driven at?
 - A. 0%
 - B. 25%
 - C. 50%
 - D. 100%
 - E. Answer not shown
22. (8 points) When $val0 = 0x3$ and $val1 = 0x0$, what is the average current through the motor?
 - A. 0 A
 - B. 0.625 A
 - C. 1.25 A
 - D. 2.5 A
 - E. Answer not shown
23. (8 points) When $val0 = 0x0$ and $val1 = 0x5$, what is the average current through the motor?
 - A. 0 A
 - B. 0.625 A
 - C. 1.25 A
 - D. 2.5 A
 - E. Answer not shown

Part IV. Control

Consider the following rotational P-D control law:

$$\tau = K_p(\theta_d - \theta) + K_v(\dot{\theta}_d - \dot{\theta})$$

Assume that positive orientation and torque both refer to the same direction.

24. (6 points) The full K_p term in the control equation can best be described physically as:
- A. a spring** B. a velocity C. a position D. friction E. Answer not shown
25. (6 points) In order to achieve critical damping, what is the sign of K_v ?
- A. $K_v > 0$** B. $K_v < 0$

Consider the two phase diagrams:

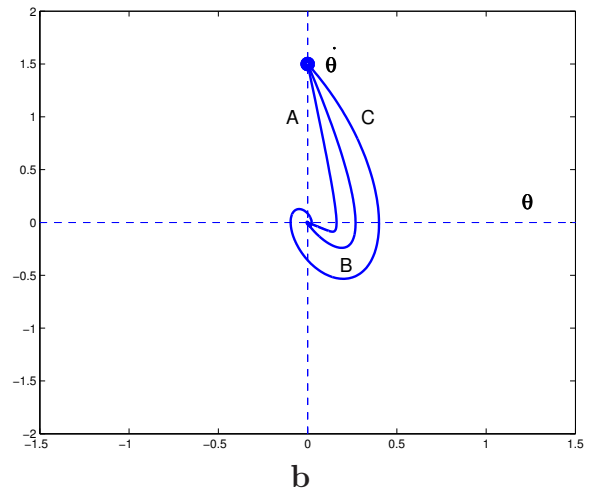
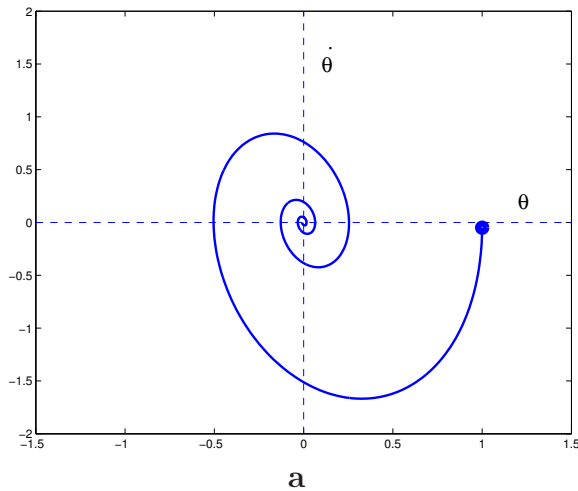

Note: assume the control equations on the previous page and that $\dot{\theta}_d = 0$ for all time. Also assume that the initial configuration corresponds to the large, filled dot.

26. (6 points) In phase diagram **b**, changing the system behavior from trajectory A to trajectory B can be accomplished by which of the following?
- K_p can be decreased or K_v can be decreased.
 - K_p can be decreased or K_v can be increased.
 - K_p can be increased or K_v can be decreased.**
 - K_p can be increased or K_v can be increased.
 - Answer not shown.
27. (6 points) In phase diagram **a**, what can be changed in order to improve the performance of the system?
- K_p can be decreased or K_v can be decreased.
 - K_p can be decreased or K_v can be increased.**
 - K_p can be increased or K_v can be decreased.
 - K_p can be increased or K_v can be increased.
 - Answer not shown.

Part V. Interrupt Service Routines

Consider the following code:

```
volatile uint8_t d = 100;

void myISR() {
    static uint8_t x = 0;
    ++x;
    if(x == d) {           // equal
        GPIOD_PDOR ^= 0x40; // XOR
        x = 0;
    }
}

int setup() {
    // Configure PORTD, bit 6 to be digital I/O
    PORTD_PCR6 = PORT_PCR_MUX(0x1);
    // Configure bit 6 to be an output
    GPIOD_PDDR = 0x40;

    // Configure the timer
    Timer1.initialize(100);
    Timer1.attachInterrupt(myISR);
    Timer1.start();

    d = ???
}

loop() {
}
```

28. (5 points) This is an example of what type of interrupt?
A. Internally-generated B. Externally-generated
29. (6 points) When $d = 10$, what is the frequency of the signal at PORT D, pin 6?
A. 10 Hz B. 100 Hz C. 1,000 Hz D. 10,000 Hz **E. Answer not shown**

Solution: 500 Hz

30. (6 points) What is the interrupt frequency?
A. 10 Hz B. 100 Hz C. 1,000 Hz **D. 10,000 Hz** E. Answer not shown
31. (6 points) When $d = 64$, what is the duty cycle of the signal at PORT D, pin 6?
A. 0% B. 25% **C. 50%** D. 100% E. Answer not shown

Part VI. Serial Processing

32. (15 points) Fill in the implementation of the following function that takes as input a character and returns -1 if the character is a lower case letter, 1 if the character is an upper case letter, 2 if the character is a numerical digit and 0 for all other characters.

```
int8_t char_type(char c) {
```

```
}
```

Solution:

```
int8_t char_type(char c) {  
    if(c >= 'a' && c <= 'z'){  
        return -1;  
    }else if(c >= 'A' && c <= 'Z'){  
        return 1;  
    }else if(c >= '0' && c <= '9') {  
        return 2;  
    }else{  
        return 0;  
    }  
}
```

33. (5 points) True or False: a start bit is used in an asynchronous serial protocol.
A. True B. False

Part VII. Digital-Analog Systems

34. (8 points) Assume an 8-bit analog-to-digital converter that uses the successive approximation algorithm, and has a range of 0 to 5 volts. If $V_{in} = 3 V$ and the first guess by successive approximation is 1000 0000, what is the sixth guess?
- A. 1001 1000 B. 1001 1001 C. 1001 1010 **D. 1001 1100**
E. Answer not shown
35. (8 points) Assume an 4-bit digital-to-analog converter with a range of 0 to 5 volts. What is the voltage that corresponds to the digital value 1001?
- A. $9/51 V$ B. $45/63 V$ C. $45/31 V$ **D. $3 V$** E. Answer not shown

Part VIII. Finite State Machines

36. (25 points) Consider a light control system for an intersection between a highway and a rural road. The behavior of the light is as follows:
1. By default, the light should be green for the highway (and red for the rural road).
 2. The only time that the rural road is given a green light is when a car is detected.
 3. Any transition from yellow to red must take 10 seconds.
 4. Any transition from red turning on along one direction to green turning on along the orthogonal direction must take 5 seconds.

The events are as follows:

- Timeout(s): s seconds have passed since timer reset. $TO(s)$
- Car detected from rural road. C
- No Car detected from rural road. NC

The actions are as follows:

- Highway(color): turn highway light to color. $HW(c)$, where c is one of R, Y, G.
- Rural(color): turn rural light to color. $R(c)$, where c is one of R, Y, G.
- Timer reset. TR .

Draw the Finite State Machine that controls these lights.

Solution: ***

Consider the following FSM:

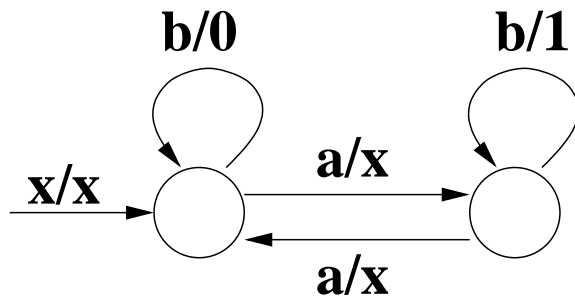

This FSM has the following inputs: x , a , b , and the following outputs:

- x = no output
- 0 = output a zero
- 1 = output a one

37. (5 points) Suppose the following sequence of inputs is given: **b, b**. What is the output?
 A. 0 **B. 00** C. 1 D. 11 E. Answer not shown
38. (5 points) Suppose the following sequence of inputs is given: **a, b, b**. What is the output?
 A. 0 B. 00 C. 1 **D. 11** E. Answer not shown
39. (5 points) Suppose the following sequence of inputs is given: **a, a, b, a, b, b, a, a**. What is the output?
 A. 01 B. 000 **C. 011** D. 111 E. Answer not shown