

Applicability and Performance of NEMO in Satellite Networks

Abu Zafar M. Shahriar
Mohammed Atiquzzaman

School of Computer Science
University of Oklahoma, Norman, OK 73019.
{shahriar, atiq}@ou.edu

William Ivancic

Satellite Networks and Architectures Branch
NASA Glenn Research Center, Cleveland, OH 44135.
wivancic@grc.nasa.gov

Abstract—Future Low Earth Orbiting spacecrafts will contain several IP-enabled devices, such as Earth observing equipment, that will be accessible by terrestrial users through the Internet. Mobility solutions, such as Mobile IPv6, can be used to handle the mobility of individual devices as the spacecraft moves around the Earth and handover between ground stations. Mobility management of individual hosts, however, results in large amount of signaling in the bandwidth-limited satellite links and manageability problem as the number of devices increases. Network Mobility (NEMO) protocols can be used for mobility management of such a group of devices moving together. In this paper, we propose an architecture for application of NEMO in satellite networks, where the devices are connected using an on-board Local Area Network. In addition to providing continuous connectivity between on-board devices from Earth, the architecture enjoys several advantages, such as reduced signaling, increased manageability and conservation of satellite link bandwidth.

I. INTRODUCTION

Spacecrafts and satellites in space contain devices and instruments to sense and takes measurements of Earth and space. Low Earth Orbiting (LEO) satellites handover between ground stations as they rotate around the Earth. Future LEO satellites will contain several IP-enabled devices that are accessible through ground stations by users on Earth. As the spacecraft moves around the Earth, mobility solution, such as Mobile IPv6 can be used to handle the mobility of the devices when satellites handover between ground stations.

Mobility of devices, such as those on-board a spacecraft, while connected to the Internet is called host mobility. Existing location-based addressing scheme of the Internet, where addresses valid in a geographical area is not valid in other areas do not permit host mobility.

To allow host mobility, Internet Engineering Task Force (IETF) designed Mobile IP (MIP) [1] and MIPv6 [2]. Although MIP or MIPv6 solves the problem of host mobility, it suffers from signaling overhead, handoff latency and inefficient routing. Fu et al. proposed SIGMA [3] that solves the problems of MIP-based solutions and can be applied to handle mobility of a node on-board a satellite. National Aeronautics and Space Administration (NASA) has been experimenting with the use of Internet protocols for satellite communications [4]. Application of MIP to satellite networks has been proposed by Israel et al. [5] where an on-board device is considered a mobile host with mobility management agents residing in terrestrial networks.

Host mobility management protocols, such as MIP or SIGMA, are not effective in managing the mobility of hosts that are moving together, such as in a vehicle, train or satellite. This is due to significant signaling overhead, increased power consumption and requirement for each host to have powerful transceiver to communicate with the access router. Moreover, simple devices incapable of running the complex protocols (for example, MIP and SIGMA) due to limited resource and processing capability, are unable to communicate with the outside world. To efficiently manage aggregate mobility of hosts, IETF has proposed NETwork MObility (NEMO) where hosts that move together are connected in a Local Area Network (LAN), and a router, called mobile router, in the LAN manages the mobility of all the hosts. NEMO Basic Support Protocol (NEMO BSP) [6], a logical extension of MIPv6, is known to perform better than MIPv6 for aggregate mobility management of a large number of hosts [7].

Future satellites will contain multiple IP-enabled de-

vices (such as camera, sensors, recording devices etc.) that are connected to IP-based terrestrial networks through an on-board LAN and ground stations. As the satellites connect to different ground stations due to their rotation around the Earth, connections to on-board IP-enabled devices have to be handed off between ground stations. Managing the mobility of on-board devices in an aggregate fashion can result in better utilization of satellite resources, such as limited device processing capability and on-board power availability. Leung et al. [8] present the application of IPv4 based mobile network on-board a satellite for management of mobility of devices in an aggregated way. Based on concepts similar to NEMO, Shi et al. [9] proposes a satellite constellation network architecture. The architecture proposed in [9] allows satellite nodes in a network to communicate through satellite mobile routers while the relative movement of the satellite nodes are transparent outside the network. The *objective* of this paper is to investigate the applicability of NEMO for mobility management of on-board IP-enabled devices. NEMO can be used to manage mobility of on-board IP-enabled devices by connecting them in a LAN with a mobile router managing mobility on behalf of the devices.

Due to large distances between ground stations, connection to terrestrial networks are unavailable for a long period during handoff between ground stations. Continuity of connection can be maintained by handing off a mobile router on-board a satellite to a mobile router on-board another satellite. The later mobile router might be connected to the terrestrial network in the same manner creating a multi-hop communication path. We *intend* to use the concept of nested NEMO, a mobile network connected to another mobile network, to achieve this multi-hop communication to the terrestrial network.

Aggregate mobility management requires a single device which is capable of running complex mobility algorithms and also lowers bandwidth requirement due to reduced signaling. Moreover, maintaining continuous connectivity to terrestrial network requires multi-hop communication. Our *contributions* in this paper are: (i) Application of NEMO BSP to aggregate mobility management of on-board IP-enabled devices in satellites, and (ii) advocate the use of nested NEMO for multi-hop communication when direct connection to ground stations are not available. We argue that despite disruption in link connectivity of satellites to ground stations, NEMO BSP can provide continuous IP connectivity between on-board devices in satellites and terrestrial networks.

The rest of the paper is organized as follows. Sec. II presents the architecture and basic protocol of NEMO.

Application of NEMO-based mobility management for satellite networks is presented in Sec. III. A discussion on performance evaluation of NEMO in satellite network is outlined in Sec. IV followed by conclusions in Sec. V.

II. NEMO

In this section, we present the architecture and basic protocol of NEMO from IETF [6]. This will help the reader to understand the adaptation of NEMO to satellite networks in Sec. III.

A. NEMO Architecture

Fig. 1 shows the architecture of NEMO. To manage the mobility of nodes in a network collectively, one or more Mobile Routers (MR) act as gateways for the nodes which could be of different types. A Local fixed Node (LFN) does not move with respect to the mobile network. A Local Mobile Node (LMN) can move to another mobile network whereas a Visiting Mobile Node (VMN) can get attached to the mobile network. A node in the mobile network can even be an MR itself with an entire mobile network behind it that forms a nested NEMO i.e. a mobile network connected to another mobile network. All nodes in a mobile network reach the Internet through the MRs. During movement of a mobile network, MRs perform handoff and keep the movement transparent to nodes in the mobile network. The network to which a mobile network is usually connected is called the home network of the mobile network. A Home Agent (HA) in the home network keeps track of the location of the mobile network.

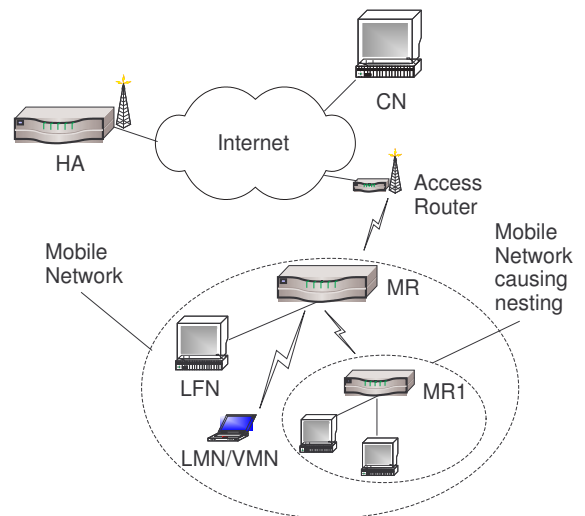

Fig. 1. Architecture of NEMO [6].

B. NEMO Basic Support Protocol

An MR registers with the HA and acquires a Home Address (HoA) through which it is reachable in the home network. MRs are also delegated one or more address prefixes to use inside its network. Prefix delegated to an MR is aggregated in the prefix advertised by HA in the home network of MR. When the mobile network moves out of its home network to a foreign network, the MR obtains a new address called Care-of-Address (CoA) from the foreign network and sends a Binding Update (BU) to its HA informing the new CoA. In addition to setting a bit in the BU to indicate that the MR is now acting as a router, it also contains the prefix of the mobile network. The BU procedure is similar to that of MIPv6 except setting of the extra bit and sending prefix information. HA sends a positive Binding Acknowledgement (BA) to indicate that forwarding to the MR is set and creates a binding cache entry that maps the HoA and prefixes of MR to the CoA of the MR. Once the binding process is completed, a bi-directional tunnel [10] is established between the HA and the MR, and HA tunnels all subsequent packets for the mobile network to the MR.

Fig. 2 shows the routing of packets for LFN1. When a node outside the mobile network (called Correspondent Node (CN)) sends a packet to a node in the mobile network, the packet is routed towards the HA. The packet is then encapsulated and tunnelled by the HA to the MR which receives, decapsulates and forwards the packet to the destination node. Packets in the reverse direction also follow the same path.

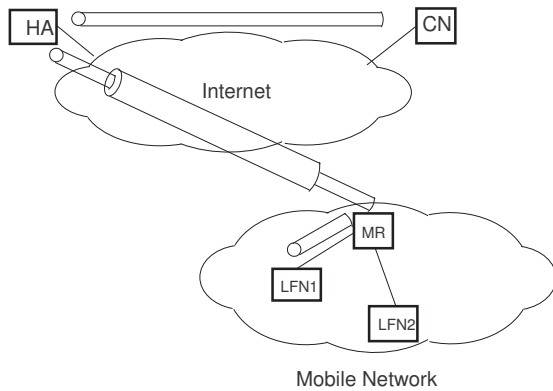

Fig. 2. Routing for LFN using bi-directional tunnel.

Fig. 3 shows packets going from CN to LFN2 through multiple tunnels in a nested mobile network. Since LFN2 obtains its address from MR2's prefix (which is obtained

from MR2's home network), the packets are intercepted by HA_MR2 which encapsulates and tunnels the packets to MR2. Since MR2's CoA is obtained from MR1's prefix, the packets are intercepted by HA_MR1 which again encapsulates and tunnels them to MR1, resulting in multiple encapsulations. Encapsulated packets on reaching MR1 are decapsulated and forwarded to MR2, which again decapsulates the packets and forwards them to LFN2. As can be seen above, two encapsulations are required for a single level of nesting; in general, the number of encapsulations increases with the nesting level and is one more than the nesting level.

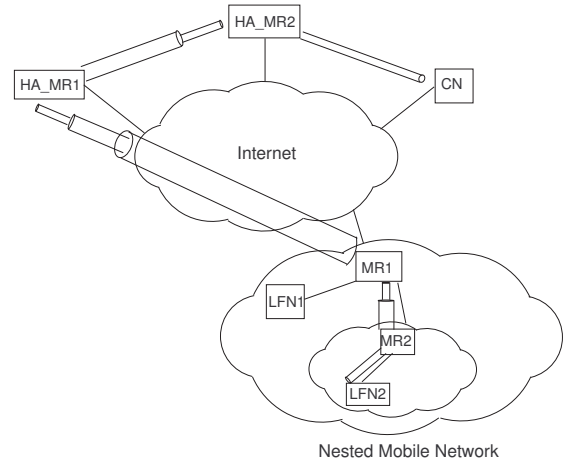

Fig. 3. Multiple tunneling in nested mobile network.

III. NEMO IN SATELLITE

In this section, we present an architecture to illustrate the application of NEMO to satellite networks and the handoff decision procedure.

A. Basic NEMO in satellite network

Fig. 4 shows the architecture for NEMO in satellite. Satellites carry on-board equipment for data collection. These IP-enabled equipment can be considered as mobile nodes in space. If the on-board equipment (e.g. LFN1, LFN2) are connected to a Local Area Network with an MR on-board a satellite, the mobility of the nodes can be managed in an aggregated fashion by considering the LAN as a mobile network and managing the mobility of the LAN (in contrast to individual nodes as in Mobile IP) by the MR. Other key features of the architecture are as follows:

- Home network of the mobile network is in the terrestrial network where the HA_MR resides.

- MR communicates with the HA_MR over the satellite links.
- Mobile network in the satellite is handed off between access routers AR1 and AR2. Access routers are co-located with ground stations on the Earth.
- CN can be any node in terrestrial network that is downloading data from on-board devices.

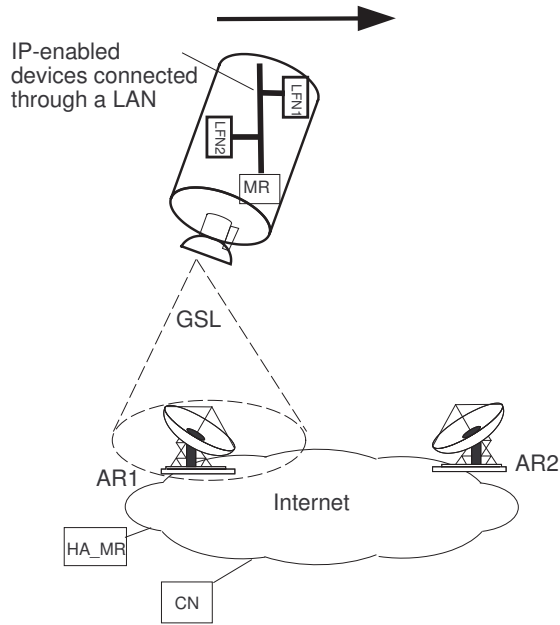

Fig. 4. Proposed architecture of NEMO in satellite.

NEMO BSP (described in Sec. II-B) can be used to handle mobility of this mobile network in the satellite. In this architecture, we only consider LFNs as it is not practical to have LMNs or VMNs inside a satellite. Since ARs co located with ground stations are far apart on the Earth, handoff latency between ARs will be large. To reduce the handoff latency, nested NEMO can be used that allows an MR on-board a satellite to communicate with ARs through MRs on-board other satellites.

B. Nested NEMO in satellite network

The architecture presented in Sec. III-A has the problem of suffering from discontinuity of IP connectivity to terrestrial networks when a ground station is unreachable from a satellite. Nested NEMO can solve this problem of discontinuity. An MR on-board a satellite, unable to find a ground station within its range, can handoff to an MR in another satellite having connectivity to a ground station. In Fig. 5, MR1 loses connection with AR1 and hands off to MR2 which is connected to AR2. Thus MR1 becomes nested under the mobile network of MR2 and maintains its connectivity to terrestrial networks. It is possible that

an MR could be connected to the terrestrial network with multiple MRs in between, creating multiple level of nesting. Since the satellites are connected to ground stations for a brief period of time, nested NEMO can provide continuous IP connectivity to terrestrial networks.

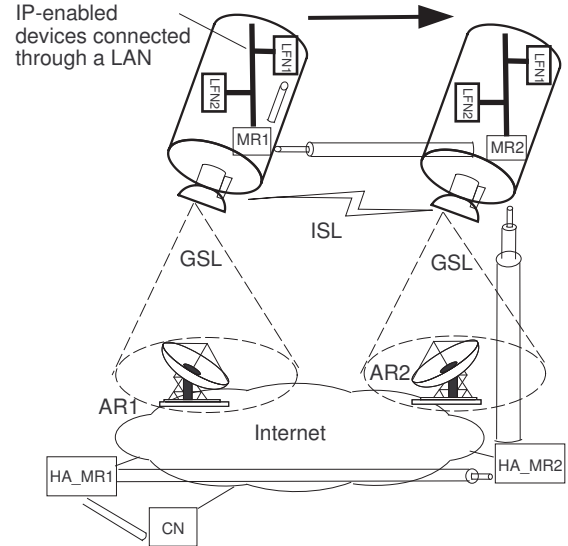

Fig. 5. Proposed architecture of NEMO in satellite.

Since multiple MRs can be available for handoff, problem of selection of the best possible MR can arise to minimize nesting level and handoff frequency. Sec. III-C discusses the issues related to best MR selection problem.

C. Best MR selection for handoff

As shown in Fig 6, a satellite can have more than one link level connection simultaneously - Inter Satellite Link (ISL) to connect to other satellites and a Ground to Satellite Link (GSL) connected to ground stations. Therefore, a satellite can receive router advertisement from both ARs in terrestrial network and MRs in the satellite network. In this case, several options may exist for choosing an MR/ AR for handoff. Considering the large propagation delay between satellites, it might be efficient to handoff to an MR/AR with lower nesting level. If this selection leads to a short connection duration with the selected MR, frequency of handoff will be high resulting in poor performance. Therefore, best MR selection requires information regarding neighboring MRs for selection of the potential best MR for handoff.

1) *Information required for MR selection:* To select the best MR for handoff, following information can be included in the router advertisement or maintained as state information at an MR:

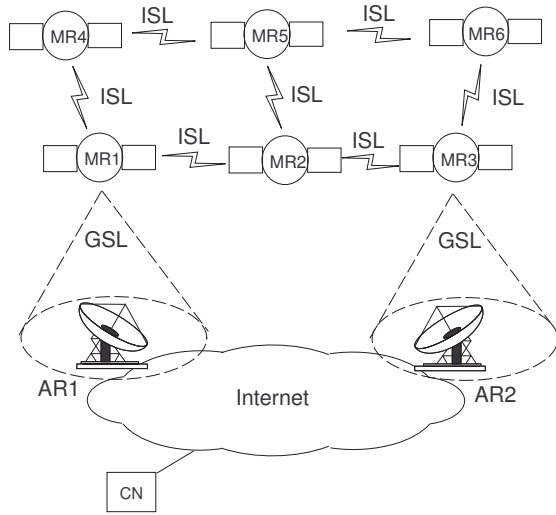

Fig. 6. MRs connected to multiple neighboring MRs at link level.

- **MR/AR indicator:** This information indicates whether the source of router advertisement is an MR or an AR. Since ARs reside in the terrestrial network, handing off to an AR will yield better performance.
- **Nesting level:** Nesting level of the sender of router advertisement is another parameter that can help in making hand off decision. Since distance between satellites is large, handoff to an MR with a lower nesting level yields significantly lower end to end delay. Moreover, the number of intermediate MRs between an MR and the AR increases with the increase of nesting level of the MR. Therefore, increase of nesting level increases the chance of connection disruption due to handoff of intermediate MRs.
- **Frequency of handoff in recent times:** Every handoff results in handoff latency. So, it might not be always beneficial for an MR to handoff to another MR with low nesting level because it may result in yet another handoff latency period when handoff frequency of the former MR, in recent past, is very high.
- **Information about neighboring MRs:** An MR can maintain information about neighboring MRs. These information can be collected and updated from router advertisement received from other MRs. Information about nesting level, average connectivity period of a neighboring MR and time period of current connection of that MR might be useful information for selection of an MR to handoff.

2) *Evaluation of available information:* Selection of an MR for handoff to optimize performance is not straight

forward. Evaluation of a neighboring MR for making handoff decision can be a complex function of current nesting level of the MR, nesting level of neighboring MRs, average connectivity period of a neighboring MR, whether neighbor is an MR or an AR, time since last handoff and frequency of handoff in recent times. To determine average inter-handoff connectivity period of an MR, extensive statistical study of movement pattern of the MRs is required. For deterministic movement pattern, exact determination of this connectivity period is possible. In this article, we provide the following guidelines for selection of an MR.

- *When connected to a AR:* An MR will simply ignore router advertisements from other MRs. Handoff will be initiated by an MR only when it loses connection with AR. This is the same criteria that is used in terrestrial network as far as IP connectivity is concerned.
- *When connected to an MR:* In this case, the MR is nested. A router advertisement from an AR must initiate a handoff. This handoff decision will reduce the level of nesting of the MR to zero resulting in smaller Round Trip Time (RTT) and fewer level of encapsulation. Because link level connection establishment with and router advertisement reception from ground station happens while the MR is continuing data transfer through other link, handoff delay is small. Moreover, connecting to a ground station ensures connectivity for a certain period of time. On reception of a router advertisement from neighboring MRs, an MR can update the information list of MRs, evaluate the MRs for handoff based on some criteria and may initiate handoff.
- *When connection is lost:* An MR can evaluate the MRs in the information list for selection of the possible best MR and probe the selected MR for handoff.

We believe that giving the highest selection priority to an AR followed by selecting an MR with lower nesting level will result in the optimal data transfer and handoff performance. This can only be verified by extensive performance evaluation as described below.

IV. PERFORMANCE EVALUATION CONSIDERATIONS

Usually devices (LFNs) collect data that are downloaded by CNs in the terrestrial networks. TCP, which is widely used transport protocol in terrestrial network, is not suitable for satellite networks because of the following characteristics of satellite links:

- Lack of congestion in satellite links.

- Brief period of connectivity with ground stations resulting in discontinuity in IP connectivity.
- High asymmetry of uplink/downlink (unable to support sufficient feedback required by TCP).

Currently, Saratoga [11] is being used as a file transfer protocol to download data files from satellites like UK-DMC. Saratoga is intended for efficient use of one hop links having brief period of connectivity and has the following characteristics:

- It uses UDP as underlying transport protocol.
- Considering brief period of connectivity of satellites to ground stations, it tries to send as much data as possible when the link is connected. New version of Saratoga has the provision of congestion control if sufficient feedback path is available.
- Uses less feedback information for loss recovery considering high asymmetry of uplink and downlink of satellite links.
- Capable of resumption of data transfer from the position where it was left off.

We evaluated performance of NEMO BSP for terrestrial network by ns-2 simulation in our previous work [7]. To evaluate performance of NEMO BSP in satellite networks, we adapted previous simulation of NEMO BSP for satellite networks. Currently, we are working on to simulate Saratoga that can perform reliable data transfer with minimal feedback information from the receiver.

V. CONCLUSION

In this paper, we study the applicability of NEMO BSP for mobility management of devices on-board a satellite. We also present possible handoff scenarios, selection of an MR/AR for handoff, and nested NEMO scenarios in satellite networks. Nested NEMO can provide continuous connectivity to on-board devices loss of connectivity with ground stations. Since nesting results in encapsulation and increased end-to-end delay, selection of an appropriate MR/ AR for handoff with low level of nesting can lead to better performance. Our future work is to use a satellite link friendly protocol to evaluate the performance of NEMO BSP in satellite network by simulation.

REFERENCES

- [1] C. Perkins, "IP mobility support for IPv4," RFC 3220, January 2002.
- [2] D. B. Johnson, C. E. Parkins, and J. Arkko, "Mobility support in IPv6," RFC 3775, June 2004.
- [3] S. Fu and M. Atiquzzaman, "SIGMA: A transport layer handover protocol for mobile terrestrial and space networks," in *e-Business and Telecommunication Networks*, J. Ascenso, L. Vasiu, and C. Belo, Eds. Springer, 2006, pp. 41–52.
- [4] W. Ivancic, P. Paulsen, D. Stewart, D. Shell, and L. Wood, "Secure, network-centric operations of a space-based asset - an abridged report," in *Earth-Sun System Technology Conference*, College Park, MD, June 28-30, 2005.
- [5] D. Israel, R. Parise, K. Hogue, and E. Criscuolo, "Space communication demonstration using Internet technology," <http://ipinspace.gsfc.nasa.gov/documents/ITC02-CANDOS.doc>, 2002.
- [6] V. Devarapalli, R. Wakikawa, A. Petrescu, and P. Thubert, "Network MObility (NEMO) basic support protocol," RFC 3963, January 2005.
- [7] A. Z. M. Shahriar and M. Atiquzzaman, "Network mobility in satellite networks," in *NASA Science Technology Conference*, College Park, MD, June 19-21, 2007.
- [8] K. Leung, D. Shell, W. D. Ivancic, D. H. Stewart, T. L. Bell, and B. A. Kachmar, "Application of Mobile-IP to space and aeronautical networks," *IEEE Aerospace and Electronic Systems Magazine*, vol. 16, no. 12, pp. 13–18, 2001.
- [9] D. Shi and C. Tang, "The handoff study on satellite networks based on mobility network," in *6th International Conference on ITS Telecommunications*, Chengdu, China, June 21-23, 2006, pp. 1029–1032.
- [10] A. Conta and S. Deering, "Generic packet tunneling in IPv6 specifications," RFC 2473, December 1998.
- [11] L. Wood, "Saratoga a bundle convergence layer," Presentation, Delay-Tolerant Networking session IETF 69, Chicago, July 2007.